

ANALOG INDUCTIVE PROXIMITY SENSOR (CURRENT AND VOLTAGE OUTPUT)

Diameter
● Shielded ○ non-Shielded
Switching Distance, Sn: mm
Housing Material
● With LED ○ Without LED

Q40
●
6-15 mm
PBT
○

Q40
○
7-20 mm
PBT
○

Picture

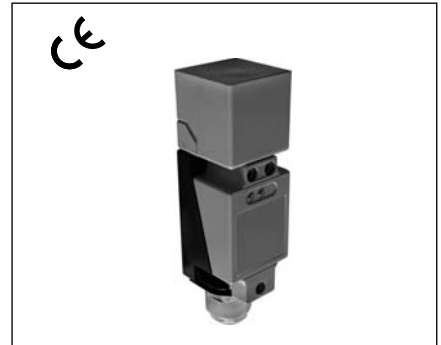

Dimensions (unit: mm)

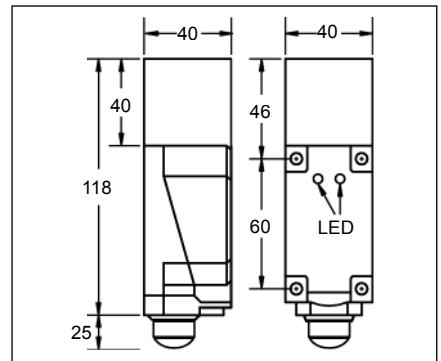
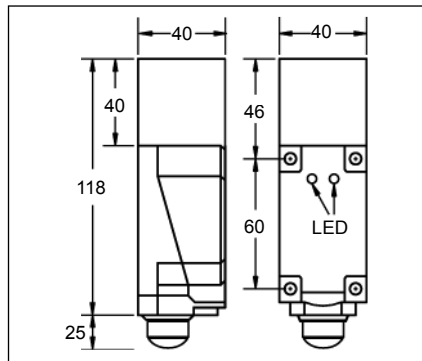

Characteristics

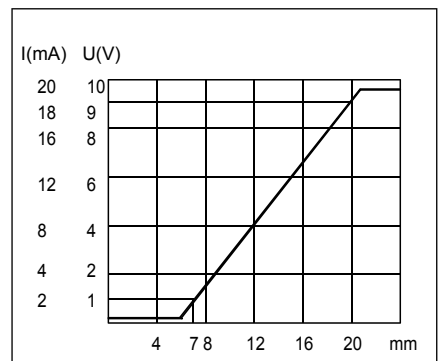
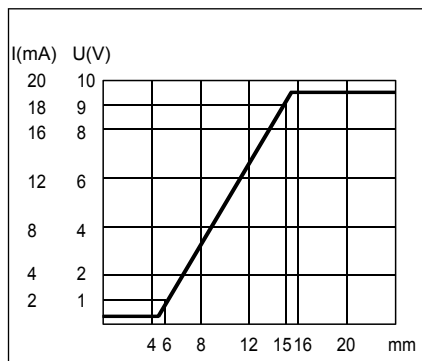

Max. Ripple
No Load Current
Output Current & Voltage /Load Resistor
Linearity
Repeat Accuracy
Ambient Temperature
Temperature Drift
Short Circuit Protection
Reverse Polarity Protection
Protection Category
Output Signal
Switch Frequency Max.
EMC
Shock / Vibration
Material Active Face
Connecting type
Weight

<10%
<15mA
0-20mA / 200 Ω Max. 0-10VDC / ≥4.7K Ω
<10%
0.02mm
-25°C - +70°C
<5%(Sr)
-
Yes
IP67
PNP-ANALOG
100Hz
RFI>3V/m / EFT>1KV / ESD>4KV (contact)
IEC 60947-5-2, Part 7.4.1 / IEC 60947-5-2, Part 7.4.2
PBT
Terminal
approx.245 g

<10%
<15mA
0-20mA / 200 Ω Max. 0-10VDC / ≥4.7K Ω
<10%
0.02mm
-25°C - +70°C
<5%(Sr)
-
Yes
IP67
PNP-ANALOG
100Hz
RFI>3V/m / EFT>1KV / ESD>4KV (contact)
IEC 60947-5-2, Part 7.4.1 / IEC 60947-5-2, Part 7.4.2
PBT
Terminal
approx.245 g

Analog Current & Voltage Output (18-30VDC)

IPS-Q4015G-M5TN	21*
-----------------	-----

IPN-Q4020G-M5TN	21*
-----------------	-----

* Wiring diagram number. Please see the relevant wiring diagram shown on Page 013 to Page 015.