

EXTENDED RANGE INDUCTIVE PROXIMITY SENSOR (10-30VDC/10-55VDC/5-36VDC)

Diameter
● Shielded ○ non-Shielded
Switching Distance, Sn: mm
Housing Material
● With LED ○ Without LED

M12	
●	○
4 mm	8 mm
Nickel plated brass	
●	

M12	
●	○
4 mm	8 mm
Nickel plated brass	
●	

Picture



Dimensions (unit: mm)

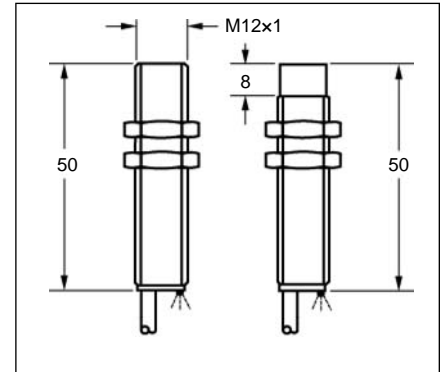
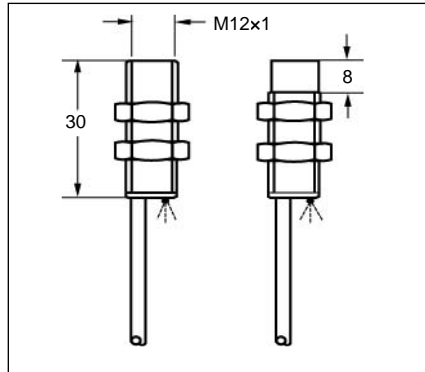

Ripple
No Load Current
Max. Load current
Leakage Current
Voltage Drop
Switching Frequency
Response Time
Switching Hysteresis
Repeat Accuracy
Protection Category
Operating Temperature
Temperature Drift
Short Circuit Protection
Overload Trip Point
Material Active Face

<10%
<10mA
200mA
<0.01mA
<2.0V
1KHz 500Hz
0.2ms/0.2ms 0.5ms/0.5ms
<15%(Sr)
<1.0%(Sr)
IP67
-25°C - +70°C
<10%(Sr)
Yes
220mA
POM PBT

<10%
<10mA
200mA
<0.01mA
<2.0V
1KHz 500Hz
0.2ms/0.2ms 0.5ms/0.5ms
<15%(Sr)
<1.0%(Sr)
IP67
-25°C - +70°C
<10%(Sr)
Yes
220mA
POM PBT

Connecting type
Weight

2M Cable (4.0 φ 3x0.25)
approx.60 g

2M Cable (4.0 φ 3x0.25)
approx.70 g

DC 3 wire 10-30V NPN N.O.
DC 3 wire 10-30V NPN N.C.
DC 3 wire 10-30V PNP N.O.
DC 3 wire 10-30V PNP N.C.
DC 3 wire 10-55V NPN N.O.
DC 3 wire 10-55V NPN N.C.
DC 3 wire 10-55V PNP N.O.
DC 3 wire 10-55V PNP N.C.
DC 3 wire 5-36 V NPN N.O.
DC 3 wire 5-36 V NPN N.C.
DC 3 wire 5-36 V PNP N.O.
DC 3 wire 5-36 V PNP N.C.

IBS-M1204N-A1VS2	1*	IBN-M1208N-A1VS2
IBS-M1204N-B1VS2	2	IBN-M1208N-B1VS2
IBS-M1204P-A1VS2	3	IBN-M1208P-A1VS2
IBS-M1204P-B1VS2	4	IBN-M1208P-B1VS2

IBS-M1204N-A1VN2	1*	IBN-M1208N-A1VN2
IBS-M1204N-B1VN2	2	IBN-M1208N-B1VN2
IBS-M1204P-A1VN2	3	IBN-M1208P-A1VN2
IBS-M1204P-B1VN2	4	IBN-M1208P-B1VN2
IBS-M1204N-A3VN2	1	IBN-M1208N-A3VN2
IBS-M1204N-B3VN2	2	IBN-M1208N-B3VN2
IBS-M1204P-A3VN2	3	IBN-M1208P-A3VN2
IBS-M1204P-B3VN2	4	IBN-M1208P-B3VN2
IBS-M1204N-A2VN2	1	IBN-M1208N-A2VN2
IBS-M1204N-B2VN2	2	IBN-M1208N-B2VN2
IBS-M1204P-A2VN2	3	IBN-M1208P-A2VN2
IBS-M1204P-B2VN2	4	IBN-M1208P-B2VN2

* Wiring diagram number. Please see the relevant wiring diagram shown on Page 013 and Page 014.

EXTENDED RANGE INDUCTIVE PROXIMITY SENSOR (10-30VDC/10-55VDC/5-36VDC)

Diameter
● Shielded ○ non-Shielded
Switching Distance, Sn: mm
Housing Material
● With LED ○ Without LED

M12	
●	○
4 mm	8 mm
Nickel plated brass	
●	

M12	
●	○
4 mm	8 mm
Nickel plated brass	
●	

Picture

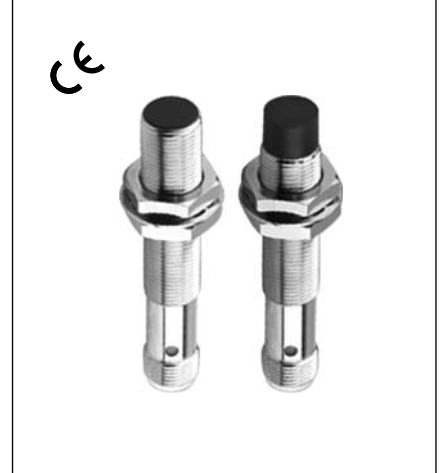

Dimensions (unit: mm)

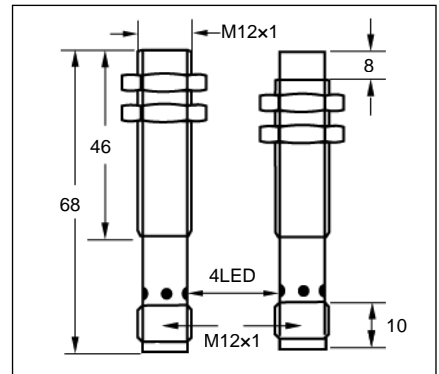
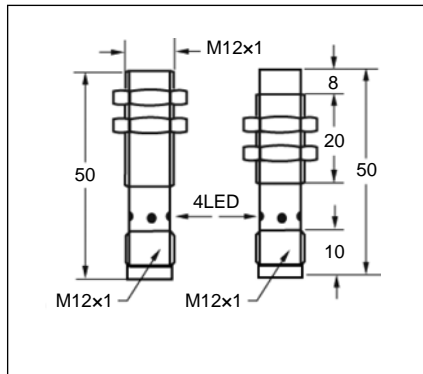

Ripple
No Load Current
Max. Load current
Leakage Current
Voltage Drop
Switching Frequency
Response Time
Switching Hysteresis
Repeat Accuracy
Protection Category
Operating Temperature
Temperature Drift
Short Circuit Protection
Overload Trip Point
Material Active Face

<10%
<10mA
200mA
<0.01mA
<2.0V
1KHz 500Hz
0.2ms/0.2ms 0.5ms/0.5ms
<15%(Sr)
<1.0%(Sr)
IP67
-25°C - +70°C
<10%(Sr)
Yes
220mA
POM PBT

<10%
<10mA
200mA
<0.01mA
<2.0V
1KHz 500Hz
0.2ms/0.2ms 0.5ms/0.5ms
<15%(Sr)
<1.0%(Sr)
IP67
-25°C - +70°C
<10%(Sr)
Yes
220mA
POM PBT

Connecting type
Weight

M12 connector
approx.25 g

M12 connector
approx.30 g

DC 3 wire 10-30V NPN N.O.
DC 3 wire 10-30V NPN N.C.
DC 3 wire 10-30V PNP N.O.
DC 3 wire 10-30V PNP N.C.
DC 3 wire 10-55V NPN N.O.
DC 3 wire 10-55V NPN N.C.
DC 3 wire 10-55V PNP N.O.
DC 3 wire 10-55V PNP N.C.
DC 3 wire 5-36 V NPN N.O.
DC 3 wire 5-36 V NPN N.C.
DC 3 wire 5-36 V PNP N.O.
DC 3 wire 5-36 V PNP N.C.

IBS-M1204N-A1ES4	1*	IBN-M1208N-A1ES4
IBS-M1204N-B1ES4	2	IBN-M1208N-B1ES4
IBS-M1204P-A1ES4	3	IBN-M1208P-A1ES4
IBS-M1204P-B1ES4	4	IBN-M1208P-B1ES4

IBS-M1204N-A1EN4	1*	IBN-M1208N-A1EN4
IBS-M1204N-B1EN4	2	IBN-M1208N-B1EN4
IBS-M1204P-A1EN4	3	IBN-M1208P-A1EN4
IBS-M1204P-B1EN4	4	IBN-M1208P-B1EN4
IBS-M1204N-A3EN4	1	IBN-M1208N-A3EN4
IBS-M1204N-B3EN4	2	IBN-M1208N-B3EN4
IBS-M1204P-A3EN4	3	IBN-M1208P-A3EN4
IBS-M1204P-B3EN4	4	IBN-M1208P-B3EN4
IBS-M1204N-A2EN4	1	IBN-M1208N-A2EN4
IBS-M1204N-B2EN4	2	IBN-M1208N-B2EN4
IBS-M1204P-A2EN4	3	IBN-M1208P-A2EN4
IBS-M1204P-B2EN4	4	IBN-M1208P-B2EN4

* Wiring diagram number. Please see the relevant wiring diagram shown on Page 013 to Page 015.